



# TECHNICAL GUIDANCE

## AM-2000 series HYBRID FLOWMETER

### GENERAL

**AM-2000** series is a new all metal type flowmeter. AM-2000 series integrates formerly separate functional devices to facilitate mounting in restricted spaces. Suitable for liquid, gas and steam applications requiring installation onto vertical pipes. Modular additional functions are integrated in basic local indicator.



### FEATURES

- ❑ Standardized total length  
Easy piping with standardized product concept of 250mm total length. (Sizes are 15mm to 100mm)
- ❑ Strong chemical properties  
Stainless steel (equivalent to SUS316L) is adopted as standard material.
- ❑ Modular parts construction  
Easy maintenance is available with modular parts.
- ❑ Adapting to CE marking to satisfy EU EMC requirements
- ❑ HART® communication protocol (Option) can be connected.
- ❑ Ex-proof type version is available. [Ex ia IIC T4, T2] and CENELEC (ATEX) certification will be available by the end of 2001.
- ❑ Ex-proof high temperature version is available [Ex ia IIC T2] (MAX. 252°C).

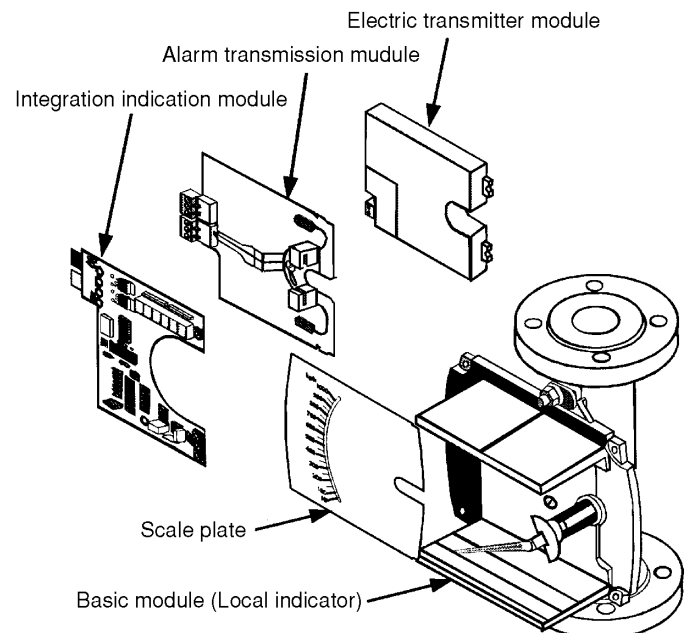

HART® is a registered trademark of the HART® Communication Foundation

**STANDARD SPECIFICATION**

- **SIZE**  
Meter size : 15mm ~ 100mm
- **CONNECTION SIZE :**  
15A ~ 100A (JIS flange)  
1/2" ~ 4" (ANSI flange)  
Note) Only JIS 20K flange is available for connection sizes 15A to 40A.  
In case of JIS 10K, the dimension is 2 mm thicker than standard dimension.  
Other flanges dimensions do not charge.
- **PRESSURE RATING**  
Flange connection : JIS 10K RF, JIS 20K RF, ANSI Class 150, 300 RF.  
Note) Max. operating pressure subjects to fluid temperature.  
Please refer to either flange rating JIS B 2238 or ASME/ANSI B16.5.
- **FLUID TEMPERATURE**  
-80 ~ +300°C (In case of no additional function)  
In case that additional function is needed, refer to below table.  
(Unit:°C)

Meter size	Additional function	Ambient temperature			
		General purpose (Non Ex)		Intrinsically safe version	
		<40°C	<60°C	T4 <60°C	T2 <60°C
15 25	E2	200	180	135	183
	E2/HT	300	300	135	252
	TZ	200	80	-	-
	TZ/HT	300	130	-	-
	K□*	200	200	135	252
50	K□*/HT	300	300	135	200
	E2	200	165	135	165
	E2/HT	300	300	135	252
	TZ	180	75	-	-
	TZ/HT	300	100	-	-
80 100	K□*	200	200	135	200
	K□*/HT	300	300	135	252
	E2	200	150	135	150
	E2/HT	300	250	135	252
	TZ	150	70	-	-
100	TZ/HT	270	85	-	-
	K□*	200	200	135	200
	K□*/HT	300	300	135	252

Note) The asterisk\* stands for :  
U/high alarm, B/low alarm, or D/high and low alarm, as the case may be.

- **AMBIENT TEMPERATURE**  
-25 ~ +120°C (No additional function)  
-25 ~ +60°C (With additional function E2/K\*/TZ)  
-20 ~ +60°C (Intrinsically Safe version)
- **MATERIAL**  
Wetted part : Stainless steel (equivalent to SS316L)  
Alumina ceramic (Al<sub>2</sub>O<sub>3</sub>)\*  
\*With damper
- **FLOW RANGE**  
25 ~ 100000 L/h (Water, 20°C)  
0.7 ~ 600 m3/h (Air, 0MPa, 20°C)
- **ACCURACY (LOCAL INDICATION)**  
: Standard ±1.6%F.S.
- **STANDARD SCALE LENGTH**  
: approx. 100mm
- **RANGE ABILITY** : 10 : 1  
(Range ability can be 10 : 2 dependent on specification)
- **INDICATOR CONSTRUCTION :**  
Protection class IP65 (IEC 529)  
Equivalent to NEMA 12/13
- **FINISH**  
Standard : Melamine resin (Painting only indicator cover)  
Color : Munsell 7.5BG4/1.5

**ADDITIONAL FUNCTIONS**

**Functions**

Function	Function code	Description
Local indication	None	Basic model
Electric transmitter	/E2	Capable of combining with all types
HART communication	/HC	Capable of combining with E2
High alarm (1points)	/KU	Choose one entry only
Low alarm (1points)	/KB	
High and low alarm (2 points)	/KD	
Total indication	/E2/TZ	Not available for intrinsically safe version (JI)
TIIS (Intrinsically safe version)	/JI	Impossible to select total indication (/TZ)
Extension for high temperature	/HT	Refer to fluid temperature specification
Cable entry 1/2NPT (F)	/NP	Choose one entry only
Cable entry G 1/2 (F)	/HG	
Cable entry Water tight connector	/MC	

Refer to type code table

**Electric transmitter (Code:E2)**

It is possible to add transmission function of 0 to 100% of flow signal with 2-wire, 4 to 20mA current output by installation of non-contact type, non hysteresis electric transmitter to local indicator of basic model.

This EST electric transmitter can be selected from intrinsically safe version under observing Japanese standard.

In addition to this, HART® communication function is available and this HART® function is also applicable to for function of multi drop. (Code : HC)

**Basic specification**

- Power supply voltage : 12 ~ 30 V DC  
18 ~ 30 V DC  
(In case of HART® selection)
- Current output : 4 ~ 20mA  
(Max output 20.4mA = 102.5%)
- Output accuracy : ±1.0%F.S.
- Repeatability : ≤ 0.1%F.S.
- Power supply fluctuation influence : ≤ 0.1%F.S.
- Load resistance influence : ≤ 0.1%F.S.

**Max load**

$$R_{ext} = \frac{\text{Supply voltage (V)} - 12V}{22(\text{mA})} \text{ (k}\Omega\text{)}$$

**Wiring**

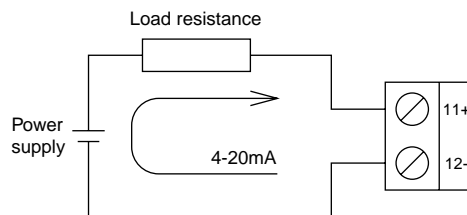

**Integrator and pulse transmitter (Code:E2/... /TZ)**

Integrator receives signal from electric transmitter and indicates total flow which is transformed into specified total rate in 6 digits in red LED. In addition, external output of scaled pulse is provided. (Open collector output)

4 to 20mA of electric transmittance can be used simultaneously.

Note) Intrinsically safe version for integrator is not available.

**TZ basic specification**

- Power supply voltage : 14 ~ 30 V DC
- Current output : 4 ~ 20mA
- Power consumption : Max 2W
- Pulse output : Open collector output
  - Pulse width 80ms (fix)
  - Power supply 10 ~ 30 V DC, Max. 50mA
  - Permissible power consumption 0.25W
- Count rate : 10 ~ 10990 c/h (Scaled to indication count)
- Integration accuracy : Within ±1.0% F.S. of current output

**Wiring**

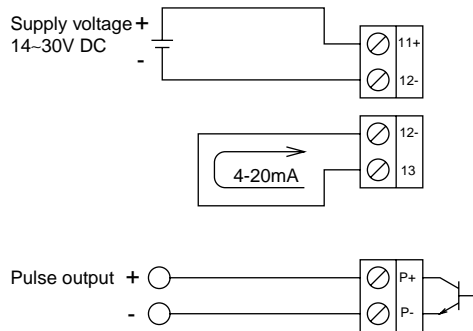

**Alarm transmitter (Code:KB/KU/KD)**

It is possible to add alarm function by installing alarm PCB to local indicator of basic model.

Low alarm, high alarm or high and low alarm can be selected for alarm mode.

- Low alarm : (Code : KB)
- High alarm : (Code : KU)
- High and low alarm : (Code : KD)

**Alarm output specification (NAMUR)**

- Type : Proximity switch SC3.5-NO-Y (NAMUR rating)
- Power supply voltage : 8 VDC
- Operating current : ON : more than 3mA, OFF : below 1mA
- Terminal No.

Alarm output	Low			High		
Plug colour	Black			Grey		
Terminal No.	1	2	3	4	5	6
Polarity	-	+	/	-	+	/

**Enclosure (Code:\*\*/JI)**

Intrinsically safe version under Japanese standard is available for additional functions such as an electric transmitter or an alarm output function and the both.

Japanese I/S standard : Ex ia IIC T4, T2  
(TIIS Certification No.C15336, C15335)

**Intrinsically safe specification of electric transmitter**

- Rating
- Max voltage for intrinsically safe circuit (Ui) : 30V
- Max current for intrinsically safe circuit (Ii) : 100 mA
- Max power consumption for intrinsically safe circuit (Pi) : 1W
- Capacitance inside intrinsically safe circuit (Ci) : 20nF
- Inductance inside intrinsically safe circuit (Li) : ≒0

**Intrinsically safe specification of alarm transmitter**

- Rating
- Max voltage for intrinsically safe circuit (Ui) : 16V
- Max current for intrinsically safe circuit (Ii) : 52 mA
- Max power consumption for intrinsically safe circuit (Pi) : 169 mW
- Capacitance inside intrinsically safe circuit (Ci) : 150nF
- Inductance inside intrinsically safe circuit (Li) : 150μH

**Extension for high temperature specification (Code:HT)**

In case application fluid temperature being over 200°C, installation of extension will be needed for protection of indication system, transmitter, etc. Indication part is extended 80 mm perpendicular to the scale plate from standard installation point and to ensure heat is insulation.

**Cable entry**

Select from following

- Water tight resin connector (Code:None/Standard)
- G1/2 (F) (Code:HG)
- 1/2NPT (F) (Code:NP)
- Water tight metallic connector (Code:MC)

**Damper**

A damper can be provided for gas or liquid application with heavy pulsation to prevent fluctuation of indication and output. A plunger for damper is made of alumina ceramic (Al<sub>2</sub>O<sub>3</sub>) which has high anticorrosive property and durability against abrasion.

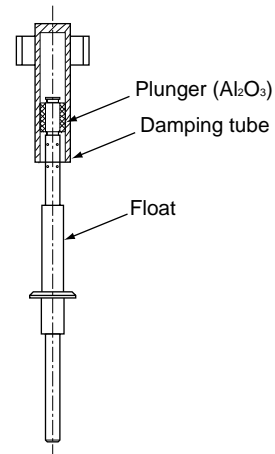

**Flow rate table**

Meter size	Q <sub>water</sub> L/h	Q <sub>air</sub> m <sup>3</sup> /h (nor)	P kPa
15	25-1000	0.7-28	2.1-5.0
25	630-6300	14-170	2.4-10.3
50	6300-25000	80-600	1.3-10.4
80	25000-40000	350-400	1.6-8.9
100	6300-100000	-	12.0

Indicated flow rate is value of 20°C water flow. Air flow rate is converted value of 0MPa (1atm) 20°C flow to 0MPa (1atm) 0°C. Both of them shows max flow range when the measurement range is 10:1.

**Selection of meter size**

1. Liquid application

Flow rates on the model code table are for liquid application equivalent to water (Sp. Gr. 1.0 and Viscosity 1.0 mPa·s). If actual fluid condition has different values, a conversion calculation is required per following formula:

$$Q_w = QX2.59X\sqrt{((7.5/\gamma)-1)}$$

Q<sub>w</sub> : Water converted flow rate (m<sup>3</sup>/h)

Q : Flow rate of actual fluid (m<sup>3</sup>/h)

γ : Specific density of actual fluid (g/cm<sup>3</sup>)

In case water converted flow rate is close to the high limit of each meter size, meter size must be selected by reference to viscosity factor in the table.

Refer to below table for viscosity limit of each meter size.

Meter size	Max water converted flow rate L/h	Upper limit of viscosity mPa·s
15	1000	30
25	6300	150
50	25000	200
80	40000	200
100	100000	200

2. Gas application

Flow rates on the model code table are measurable flow rates for air 0°C, 0MPa (1atm). If actual fluid condition has different from values, a conversion calculation is performed by the following formula:

$$Q_A = QX0.0169X\sqrt{(\gamma X (273+t))/(0.1013+P)}$$

Q<sub>A</sub> : Converted flow rate in air 0°C, 0MPa [m<sup>3</sup>/h(nor)]

Q : Flow rate of gas to be measured [m<sup>3</sup>/h(nor)]

γ : Specific weight of gas to be measured (kg/m<sup>3</sup>)

P : Operating pressure (MPa)

t : Operating temperature (°C)

## STANDARD FLOW RATE TABLE FOR LIQUID

Fluid specification : Water, Sp. Gr. 1.0 and Viscosity 1.0 cP

Meter size	Conn. size	Model code	100% Flow rate		Range ability		
			L/h	L/h	m <sup>3</sup> /h	L/min	
15	15A (1/2") 20A (3/4")	AM-21□1 AM-22□1	-1111	25	5-25	0.005-0.025	0.08-0.4
			-1211	40	8-40	0.008-0.04	0.12-0.6
			-1311	60	12-60	0.012-0.06	0.2-1
			-1411	100	10-100	0.01-0.1	0.15-1.5
			-1511	150	15-150	0.015-0.15	0.25-2.5
			-1611	250	25-250	0.025-0.25	0.4-4
			-1711	400	40-400	0.04-0.4	0.6-6
			-1811	600	60-600	0.06-0.6	1-10
25	25 (A1") 40 (1 1/2")	AM-23□1 AM-24□1	-3111	600	60-100	0.06-0.6	1-10
			-3211	1000	100-1000	0.1-1	1.5-15
			-3311	1500	150-1500	0.15-1.5	2.5-25
			-3411	2500	250-2500	0.25-2.5	4-40
			-3511	4000	400-4000	0.4-4	6-60
			-3521	6000	600-6000	0.6-6	10-100
50	50A (2") 65A (2 1/2")	AM-25□1 AM-26□1	-5111	6000	600-6000	0.6-6	10-100
			-5211	10000	1000-10000	1-10	15-150
			-5311	25000	2500-25000	2.5-25	40-400
80	80A (3") 100A (4")	AM-27□1 AM-28□1	-7111	25000	2500-25000	2.5-25	40-400
			-7211	40000	4000-40000	4-40	60-600
100	100A (4")	AM-28□1	-8112	60000	6000-60000	6-60	100-1000
			-8122	100000	10000-100000	10-100	150-1500

## STANDARD FLOW RATE TABLE FOR GAS

Fluid specification : AIR, Temperature 0°C and Pressure 0 MPa

Meter size	Conn. size	Model code	100% Flow rate		Range ability		
			m <sup>3</sup> /h	m <sup>3</sup> /h	L/h	m <sup>3</sup> /min	
15	15A (1/2") 20A (3/4")	AM-21□1 AM-22□1	-1132	0.7	0.07-0.7	70-700	0.001-0.01
			-1232	1	0.1-1	100-100	0.0015-0.015
			-1332	1.5	0.15-1.5	150-1500	0.0025-0.025
			-1432	2	0.2-2	200-2000	0.003-0.03
			-1532	3.5	0.35-3.5	350-3500	0.006-0.06
			-1632	5	0.5-5	500-5000	0.008-0.08
			-1732	10	1-10	1000-10000	0.015-0.15
			-1832	12	1.2-12	1200-12000	0.02-0.2
			-1722	18	1.8-18	1800-18000	0.03-0.3
25	25A (1") 40A (1 1/2")	AM-23□1 AM-24□1	-1822	25	2.5-25	2500-25000	0.04-0.4
			-3132	12	1.2-12	1200-12000	0.02-0.2
			-3232	20	2-20	2000-20000	0.03-0.3
			-3332	35	3.5-35	3500-35000	0.06-0.6
			-3432	50	5-50	5000-50000	0.08-0.8
			-3532	80	8-80	8000-80000	0.12-1.2
			-3422	100	10-100	10000-100000	0.15-1.5
50	50A (2") 65A (2 1/2")	AM-25□1 AM-26□1	-3522	150	15-150	15000-150000	0.25-2.5
			-5132	80	8-80	80000-800000	0.12-1.2
			-5232	100	10-100	10000-100000	0.15-1.5
			-5332	150	15-150	15000-150000	0.25-2.5
			-5342	180	18-180	18000-180000	0.3-3
			-5122	200	20-200	20000-200000	-
80	80A (3") 100A (4")	AM-27□1 AM-28□1	-5222	350	35-350	35000-350000	0.6-6
			-5322	600	60-600	60000-600000	1-10
80	80A (3") 100A (4")	AM-27□1 AM-28□1	-7132	350	35-350	35000-350000	0.6-6
			-7232	400	40-400	40000-400000	0.7-7

MODEL CODE

AM-2		<input type="checkbox"/>	<input type="checkbox"/>	<input type="checkbox"/>	<input type="checkbox"/>	<input type="checkbox"/>	<input type="checkbox"/>	<input type="checkbox"/>	<input type="checkbox"/>	<input type="checkbox"/>	Specification	Fluid : liquid		Fluid : gas		
Connection size	1										15A (1/2")	Qw (L/h) 20°C water	25~1000	Qa (m3/h) 0°C	0.7~28	
	2									20A(3/4")	630~6300				0MPa air	14~170
	3									25A(1")			6300~25000	0MPa air		80~600
	4									40A(1 1/2")	25000~40000				0MPa air	350~400
	5									50A(2")			25000~100000	0MPa air		
	6									65A(2 1/2")						
	7										80A(3")					
	8										100A(4")					
Flange rating	1									JIS 10K RF	Min. connection size 50A					
	2									JIS 20K RF	Applicable for all types					
	A								ANSI Class150 RF							
	B								ANSI Class 300 RF							
Main material	1									Equivalent to SUS316L	Only SUS316L					
Meter size	-1									Meter size 15	Connection size : 15A, 20A					
	-3									Meter size 25	Connection size : 25A, 40A					
	-5									Meter size 50	Connection size : 50A, 65A					
	-7									Meter size 80	Connection size : 80A, 100A					
	-8									Meter size 100	Connection size : 100A	X				
Inside of tapered tube										Tapered tube type	(Maker selection code)					
Float										Float type	(Maker selection code)					
Float damper	1									Not provided	15~80A : Standard	X				
	2									Provided	100A : Standard	Standard				
Additional function	Transmitter function	/E2								Electric transmitter	Applicable for all types					
		/HC								HART communication	Required to select electric transmitter					
		/KU								With high alarm (1 point)	Choose one entry only					
		/KB								With low alarm (1 point)						
		/KD								With high and low alarm (2 points)						
	/TZ								Integrator	Required to select electric transmitter, not available for intrinsically safe version						
	Weather proof	/JI								TIIS	Impossible to select total indication (/TZ)					
	High temperature	/HT								With extension	Applicable for all types					
Cable entry	/NP								NPT 1/2(F)	Choose one entry only						
	/GH								G1/2(F)							
	/MC								With metallic water tight connector							

SIZE AND WEIGHT

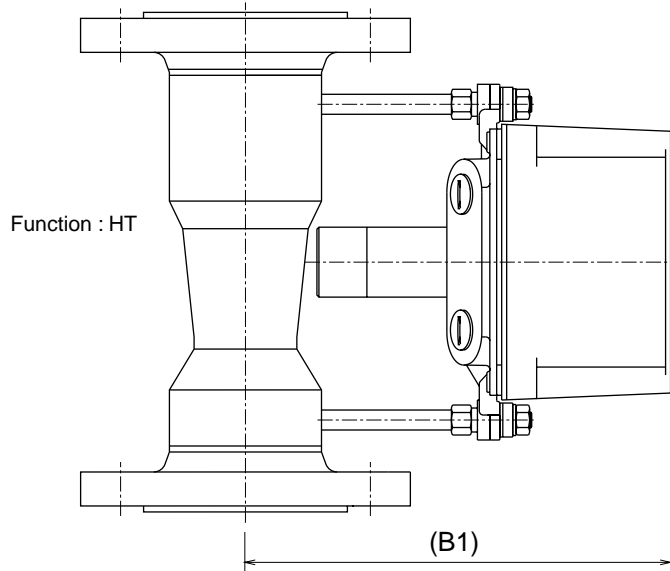
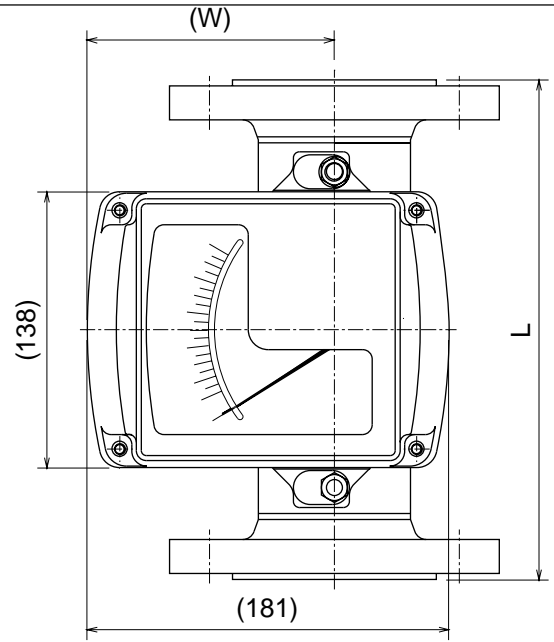
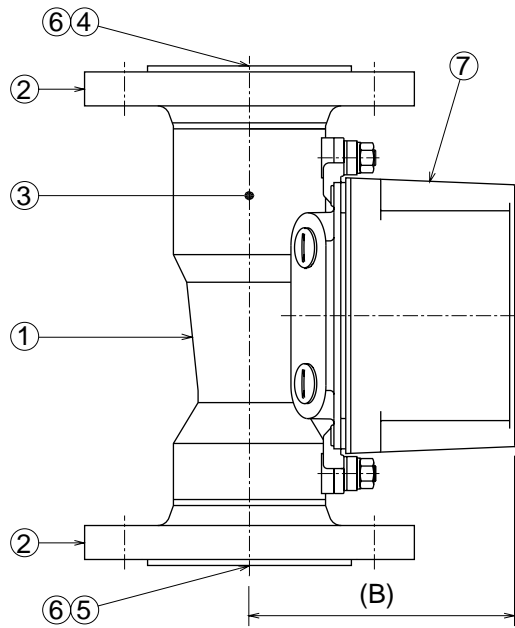

Function : HT

No.	Description	Material
①	Tapered tube	SUS316L (Equ.)
②	Flange	SUS316L (Equ.)
③	Float (ass'y)	SUS316L (Equ.)
④	Float guide	SUS316L (Equ.)
⑤	Float stop	SUS316L (Equ.)
⑥	Snap ring	SUS316L (Equ.)
⑦	Case	ADC 12
⑧	Damper	Al <sub>2</sub> O <sub>3</sub>

Note) Snap ring is assembled on upper side for meter size 15A.  
 Damper is provided only for gas or steam application for meter size 100A.  
 Additional functions such as electric transmitter, alarm transmitter unit, integration unit can be integrated inside the housing, if required.

Meter size	Connection size	Range ability				Approx. weight (kg)			
		L	B(B1)	Int. diameter d	W	JIS 10K	JIS 20K	ANSI 150	ANSI 300
15	15 (1/2")	250	107 (187)	20	110.5	-	3.6	3.5	3.6
	20 (3/4")	250				-	4.0	3.8	4.5
25	25 (1")	250	119(199)	32	110.5	-	5.6	5.2	5.2
	40 (1 1/2")	250				-	6.4	6.1	8.0
50	50 (2")	250	132 (212)	65	123.5	8.7	8.7	9.1	10.7
	65 (2 1/2")	250				10.5	10.5	11.5	13.5
80	80 (3")	250 (300*1)	148 (228)	89	123.5	12.0	14.0	15.0	18.0
	100 (100")	250 (300*1)				13.5	18.0	17.5	27.0
100	100 (4")	250 (300*1)	158 (238)	114	123.5	14.0	18.0	18.0	27.0

1\* Size within the brackets ( ) is for flange rating : ANSI300

**STANDARD SCALE GRADUATION**

Scale specification is per following 16 standard scale graduation.

Max scale is calculated by flow rate conversion after confirming actual specifications.

Therefore be sure to inform us standard flow range.

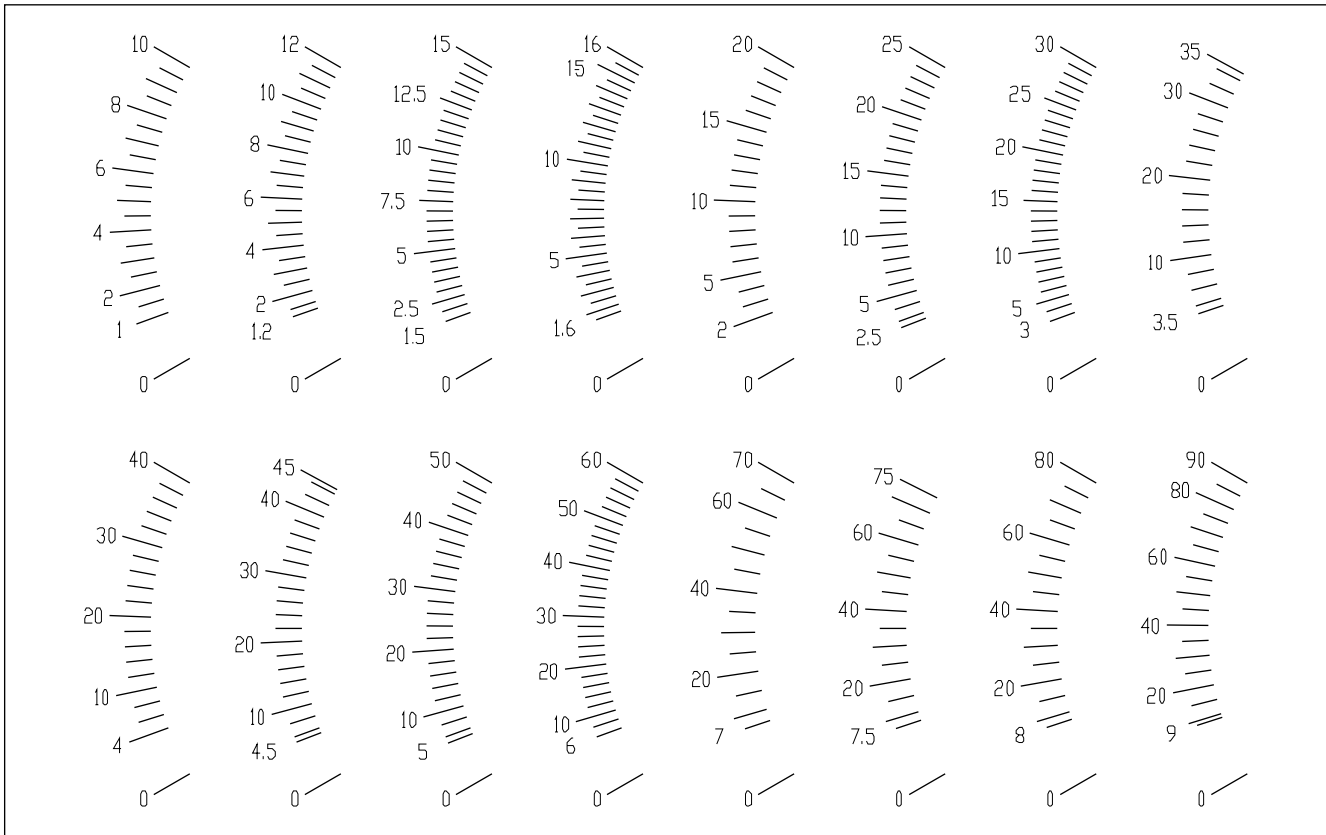

\* Specification subject to change without notice

**TIV TOKYO KEISO CO., LTD.**

Head Office : Shiba Toho Building, 1-7-24 Shibakoen, Minato-ku, Tokyo 105-8558

Tel : 03-3431-1625 (KEY) ; Fax : 03-3433-4922

e-mail : overseas.sales@tokyokeiso.co.jp ; URL : <http://www.tokyokeiso.co.jp>

